



nyloflex[®] Combi F III

Premium quality system for back, main and post exposure, drying and light finishing of flexo plates

Mid-size format, suitable for processing high quality photopolymer plates up to a maximum size of 1200 mm x 920 mm (47.2" x 36.2")

High productivity, reliability and safety due to process control

- User friendly touch screen display shows all operating information
 - 24 memory programmes to store plate processing parameters
 - Four sealed drying drawers with individual drying time settings and count down facility
- Highly efficient exhaust air extraction system with safety shut-down facility prevents solvent vapours from escaping during drying
- Service functions to analyse malfunctions: Visualisation of main sensors and the status of the PLC with alarm history
- Consistent exposure with 31 high intensity UV-A tubes (60 W) and built-in reflectors
 - Operating status of lamps is displayed
 - The operating hours of the tubes are recorded and can be displayed
 - Exposure section with airflow and cooled bed for optimal temperature control
- Automatic lid opening by pneumatic drive

Highly efficient due to a compact design and low cost

- Space saving with exposure, drying and finishing in one device
 - Exposure unit for back and main exposure
 - Light finishing drawer with UV-A tubes for post exposure, as well as UV-C tubes for light finishing
- Cost effective solution
 - All-in-one design

nyloflex® Combi F III

Equipment Dimensions

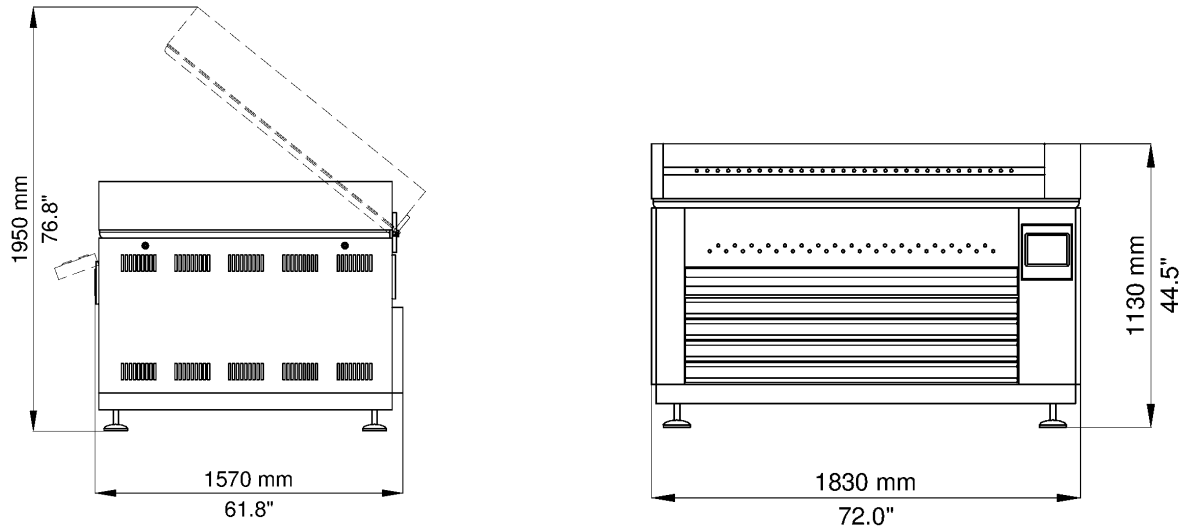

Technical data	nyloflex® Combi F III
Maximum plate size (W x L)	1200 mm x 920 mm (47.2" x 36.2")
Electrical connection	230 V, 50/60 Hz (3 Ph/PE) / 400 V, 50/60 Hz (3 Ph/N/PE)
Nominal current	25 A / 15 A
Nominal power	9.50 kW
Exhaust air flow rate	min. 550 Nm ³ /h (324 CFM)
Compressed air	Ø 6 mm, min. 6 bar, (102 PSI)
Tube type UV-A	60 W, high intensity tubes with reflector
Tube type UV-C	75 W, TUV
Vacuum foil	1400 mm (55.0")
Weight (approx.)	750 kg (1653 lbs) net 1000 kg (2205 lbs) gross
Crate dimensions (W x D x H)	1950 mm x 1950 mm x 1500 mm (76.8" x 76.8" x 59.1")
Recommended ambient temp.	20 - 25 °C (68 - 77 °F)

Please contact us for additional information.

Flint Group, Sieglestr. 25, 70469 Stuttgart, Germany • T +49 711 9816 389 • info.flexo@flintgrp.com • www.flintgrp.com

The aim of our technical documents is to inform and advise our customers. The information provided herein is correct to the best of Flint Group's knowledge. No liability for any errors, facts or opinions is accepted. Customers must satisfy themselves as to the suitability of this product for their application. No responsibility for any loss as a result of any person placing reliance on any material contained herein will be accepted. Product names followed by ® are trademarks registered by Flint Group (represented by Flint Group US LLC or Flint Group Germany GmbH). Rely on usSM is a service mark of Flint Group.